

200152

UNIVERSAL DIESEL

MODEL 20 & 30

SERVICE MANUAL

medalist 

Universal Motors

PRICE \$10.00

FORM 12-83

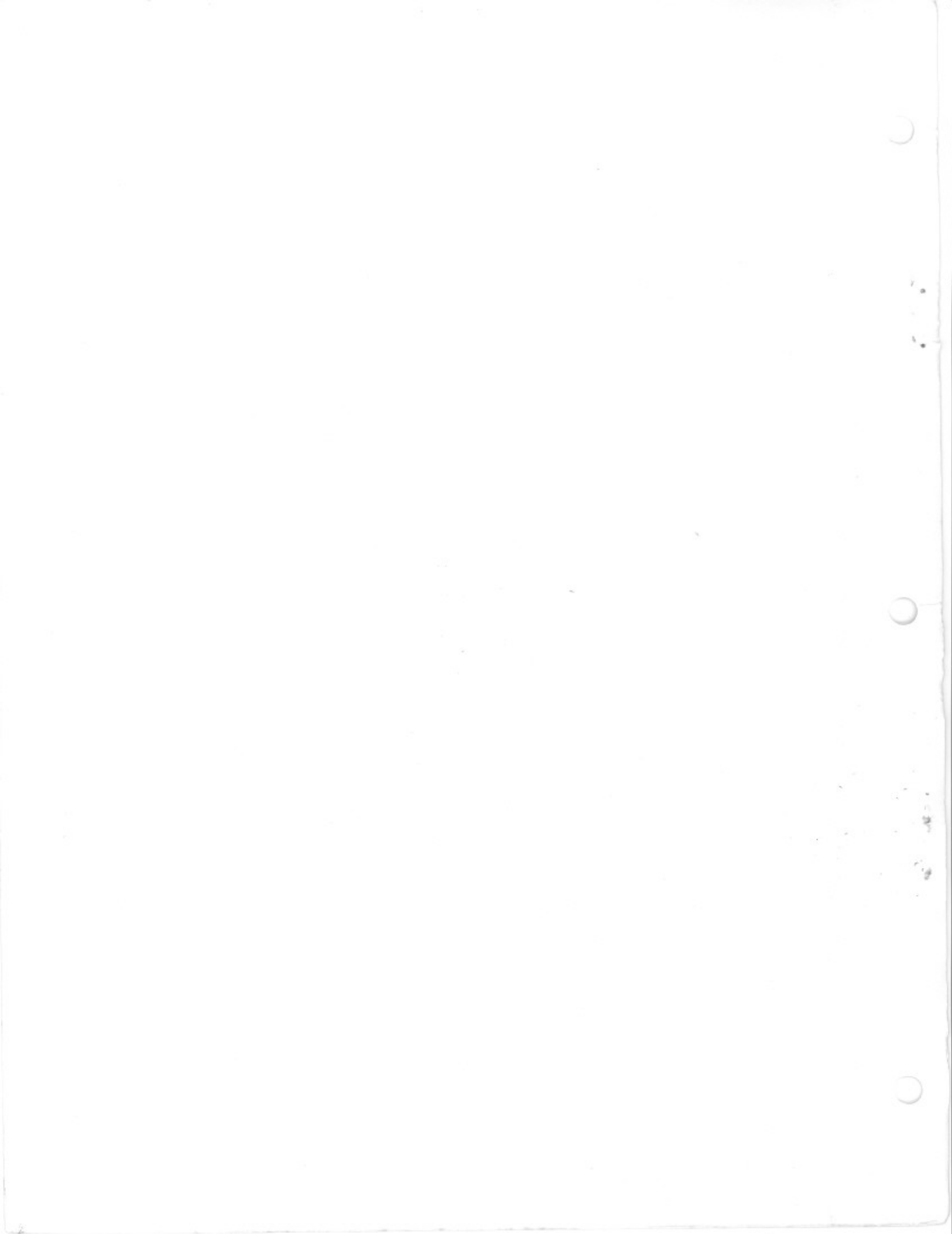

MODEL 20 & 30 INDEX

Specifications	1-2
Fuel System	3-4
Lubrication System	5-6
Oil- Filter	6
Combustion System	7
Valve Timing	8
Compression Release	9
Cylinder Liner	10
Cylinder Head	10
Piston and Rings	11
Crankshaft	11
Connecting Rod	12
Gear Train	13
Camshaft Bearings	13
Main Bearings	14
Injection Pump	15
Water Pump	16
Flywheel	16
Starting Motor	16-17
Glow Plug	17-18
Wiring Diagram	19
Reference Charts	20-24

Dec 11, 1994
904 hrs Motor -

SPECIFICATIONS



MODEL	15 (5411)	20 (5416)	30 (5424)	40 (5432)	50 (5444)
HORSEPOWER	11	16	24	32	44
NO. OF CYLINDERS	2	2	3	4	4
BORE & STROKE	2.67 x 2.75	2.99 x 3.23	2.99 x 3.23	2.99 x 3.23	3.3 x 3.25
DISPLACEMENT (CU. IN.)	31	45	68	91	115
MAXIMUM R.P.M.	3000	2800	2800	2800	3000
COMPRESSION RATIO	22:1	21:1	21:1	21:1	21:1
TYPE	Vertical, water cooled, 4-cycle diesel engine				
ELECTRICAL EQUIPMENT	12 Volt, 55 AMP Alternator, Electric Starter, & Glow Plugs Mech. Fuel Pump Fuel Pump Mech. Fuel Pump				
LUBRICATION (Engine)	2.2 Qts. 3.7 Qts. 5.6 Qts. 11.5 Qts. 8.5 Qts. Use SAE 30 HD (CD) or 10W40 heavy duty diesel lubricating oil				
LUBRICATION (Transmission) (Std and V-Drive)	Fill to full mark on dipstick. Use automatic transmission fluid Type A.				
TRANSMISSION REDUCTION	2:1	2:1	2:1	2:1	2:1
COOLING SYSTEM (7 PSI CAP)	Sea-water cooled	Fresh water 4.8Qts. 14 PSI	water cooling 6 Qts. 14 PSI	system 8 Qts. 14 PSI	8 Qts. 14 PSI
SEA WATER INLET & OUTLET	3/8" NPT				
EXHAUST FLANGE	1-1/4" NPT			1-1/2" NPT 1-1/2" NPT	
FUEL	Diesel fuel number 2-D				
FUEL INLET HOSE	5/16" I.D.				
FILTERS, FUEL OIL	298854	298854	298854	298854	298854
FILTERS, LUBRICATION OIL	299381	298852	298852	299584	299927
GOVERNOR	Centrifugal type - all speeds				

MODEL	15 (5411)	20 (5416)	↓ 30 (5424)	40 (5432)	50 (5444)
ENGINE OPERATING TEMPERATURE	135° to 150° F ----- 175° to 190° F -----				
MAX. OPERATING ANGLE	15° ALL				
ENGINE ROTATION	Clockwise when viewed from V-belt end				
PROPELLER ROTATION	Right Hand (BOTH STD. AND V-DRIVE)				
ENGINE WEIGHT (Pounds)	245	365	425	490	545
LENGTH (Overall)	25.6"	28.0"	32.5"	36.2"	36.0"
HEIGHT (Overall)	21.2"	24.1"	24.6"	26.0"	26.0"
WIDTH (Overall)	20.7"	20.7"	20.7"	20.7"	21.4"
INJECTION NOZZLE					
INJECTION TIMING	25° before top dead center - all models				

Construction and Handling

Fuel System

Fuel system

The fuel system schematic is shown in Fig. 1 with the fuel flowing in the direction indicated by the arrows. To bleed air from the system, loosen the vent plug "A" on the fuel filter and crank the engine until there are no more air bubbles from the vent. Tighten vent "A" and purge the air from the injection pump at vent "B" using the same procedures.

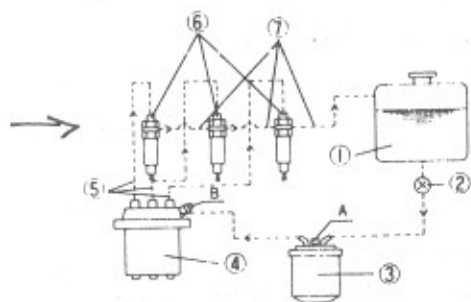
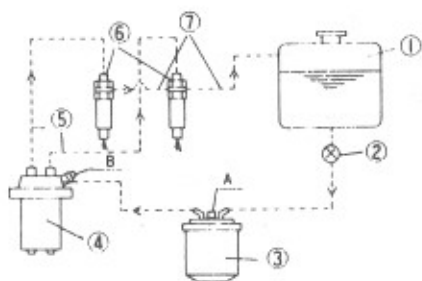

- | | |
|------------------------|----------------------|
| 1. Fuel tank | 6. Nozzle holder |
| 2. Fuel cock | 7. Overflow pipe |
| 3. Fuel filter | A: Vent plug, filter |
| 4. Fuel injection pump | B: Vent plug, pump |
| 5. Injection pipe | |

Fig. 1. Fuel System

Fuel-filter

The fuel filter is of the cartridge type shown schematically in Fig. 2. Under normal conditions it should only have to be replaced every 400 hours. To install, apply a small amount of fuel to the packing and tighten securely by hand. For removal, the use of a filter wrench 15221-86611 is recommended.

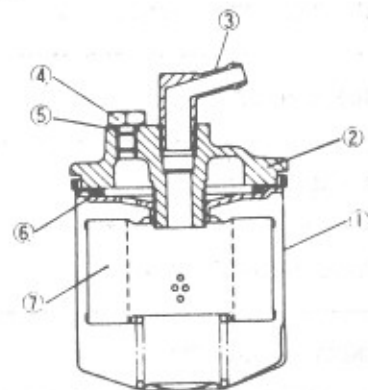

1. Fuel filter
2. Cover
3. Pipe coupling
4. Vent plug
5. "O" ring
6. "O" ring
7. Element

Fig. 2. Fuel Filter

Fuel injection timing

Fuel injection timing is adjusted by changing the number of shims used between the pump and the gear case it fits into. See Fig. 3. One shim corresponds to approximately 1.5 degrees in crank angle. Therefore, injection will take place 1.5 degrees later when a shim is added and 1.5 degrees earlier when a shim is removed. The timing is correct when the pointer in the peep-hole on the side of the flywheel housing lines up with the "F1" marked on the flywheel. See Fig. 4.

Fuel injection pump Speed control lever

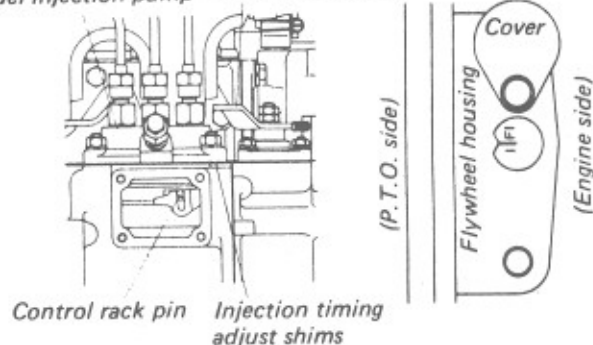

Fig. 3. Adjustment of Injection Timing

Fig. 4. Inspection of Injection Timing

Fuel injection pump

The injection pump is the Bosch "Mine K-type". It is a precision piece of equipment machined to close tolerances and its performance directly affects the performance of the engine. Therefore, handle it with care.

■ Handling the injection pump

Use care in handling and using the injection pump. As mentioned before, the injection pump is a precision piece of equipment and care should be taken not to drop it or clamp it tightly when working on it. Also, be sure to use only clean fuel that has been filtered. Oil drums left outdoors are always considered to contain water, so always filter this fuel before using.

Clean fuel is a must as the fuel is forced through parts of the pump and nozzle with clearances of 0.0004 in. (1/1000mm) which may easily be stuck or rusted by even the slightest amount of water in the fuel.

■ Installing the injection pump

When installing the injection pump, make certain that the control rack pin is correctly placed in the 0.2 in. (5mm) wide groove of the fork lever (1) before tightening the attaching bolts. Refer to the diagram. If the bolts are drawn down with the rack pin off the groove, the rack may over travel and stick in this position. This would cause excess fuel flow, allowing the engine to overspeed which would result in engine failure.

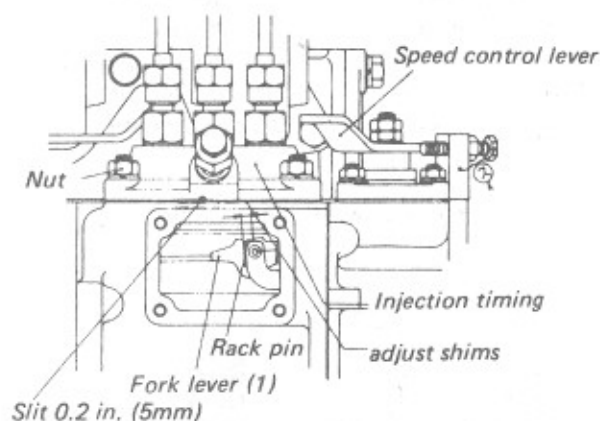
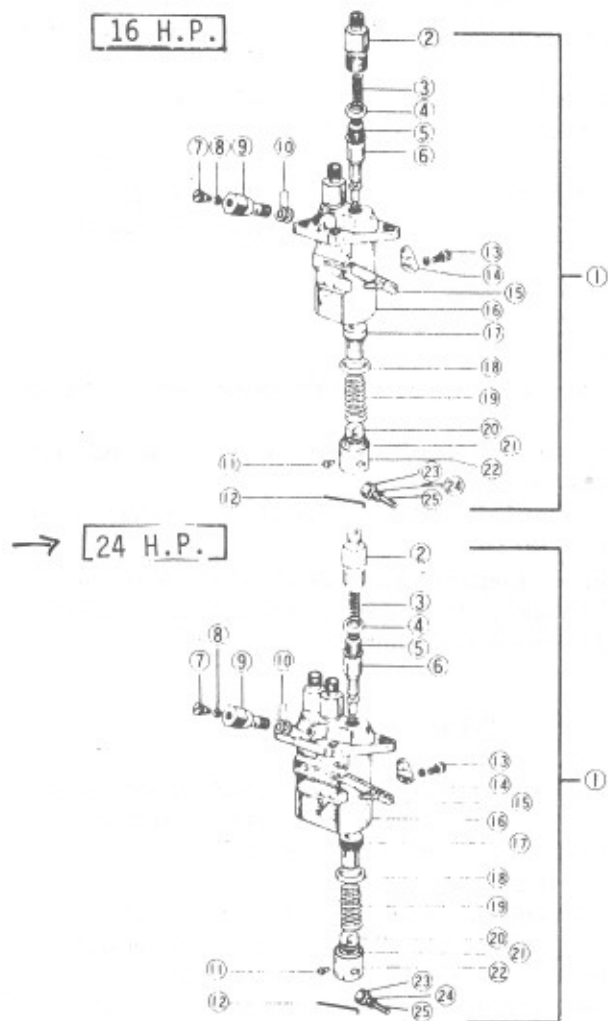

- | | |
|--------------------------|------------------------|
| 1. Injection pump ass'y | 14. Adjusting plate |
| 2. Delivery valve holder | 15. Control rack |
| 3. Delivery valve spring | 16. Pump housing |
| 4. Delivery valve gasket | 17. Control sleeve |
| 5. Delivery valve | 18. Upper spring sheet |
| 6. Cylinder pump element | 19. Plunger spring |
| 7. Air bleeder screw | 20. Lower spring sheet |
| 8. Packing | 21. Shim |
| 9. Hollow screw | 22. Tappet ass'y |
| 10. Packing | 23. Roller |
| 11. Tappet guide pin | 24. Roller bushing |
| 12. Clamp pin | 25. Roller pin |
| 13. Bolt | |

Fig. 5. Fuel Injection Pump

■ Fuel injection nozzle

The fuel injection nozzle, like the fuel injection pump, is also a precision piece of equipment and should be treated with the same amount of care.

■ The nozzle cracking pressure

The nozzle cracking pressure is adjusted by adding or subtracting shims from the top of the nozzle spring. Adding a 0.004 in. (0.1mm) shim will increase the cracking pressure by about 142 psi. (10 kg/cm²). The nozzle cracking pressure is 1990 to 2133 psi. (140 to 150 kgf/cm²)

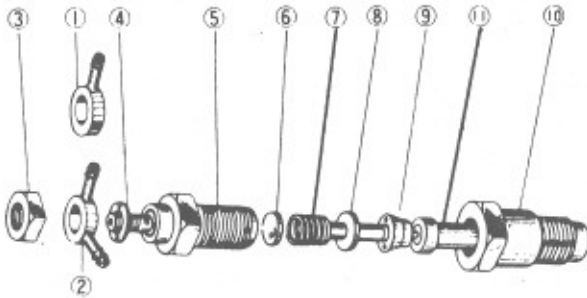

- | | |
|-----------------------|------------------------|
| 1. Delivery nipple 1 | 7. Nozzle spring |
| 2. Delivery nipple 2 | 8. Push rod |
| 3. Nut | 9. Pressure pin holder |
| 4. Washer | 10. Nozzle nut |
| 5. Nozzle holder body | 11. Nozzle piece |
| 6. Adjusting washer | |

Fig. 6. Fuel Injection Nozzle

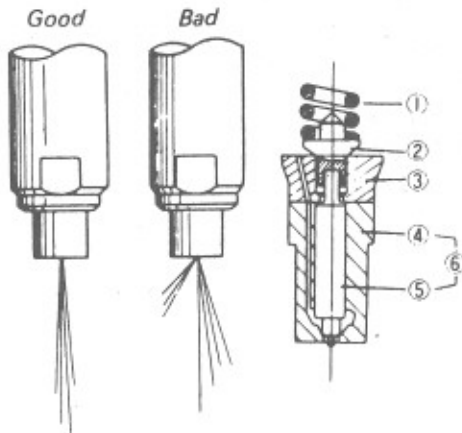

- | | |
|------------------------|-----------------|
| 1. Pressure spring | 4. Nozzle body |
| 2. Pressure pin | 5. Needle valve |
| 3. Pressure pin holder | 6. Nozzle piece |

Fig. 7. Nozzle

■ Spray pattern

The nozzle cracking pressure and fuel spray pattern are most accurately checked by using a nozzle "pop test" stand. If a "pop test" stand is not available, remove the nozzles from the engine, leaving the pressure lines connected.

[[CAUTION]]

Hold the nozzles so that the high pressure spray from them will not in any way impinge upon unprotected skin. The atomized fuel will easily penetrate the skin and cause blood poisoning.

Set the speed control lever at W. O. T. and operate the starter. The needle valve, if it is working properly, will produce a high pitched pulsating sound like that of a flute as fuel is sprayed out. If this sound is not heard or other problems are noted, refer to the "Fuel Injection Pump & Nozzle Maintenance Std." in 4.1 in "Engine".

[[Precaution]]

- (1) Assembly and disassembly of the nozzle should be done in fresh clean fuel.
- (2) The nozzle should always be installed as an assembly, never by component parts.
- (3) Remember never to let the nozzle spray contact unprotected flesh.
- (4) Tighten the retaining nut to 43.5 to 58 ft-lb (6 to 8 kgf-m) Any torque higher than this will cause slow action of the needle valve and poor injection.

2.2 Lubrication System

■ Oil pump pick-up screen

The oil pump pick-up is located in the crankcase as shown in Fig. 9 and is fitted with a metal screen. If the screen becomes plugged, wash it off with diesel fuel or kerosene.

■ Lubrication system

The entire lubrication system is illustrated in Fig. 8. Oil from the pump is forced through the replaciable paper element filter. The filter is equipped with a pressure regulated valve to keep the pressure through the filter at 64~71 psi. (4.5~5 kgf/cm²). From the filter part of the oil goes to the crankshaft to lubricate the crankpins and the remainder goes to lubricate the rocker arms.

An oil pressure switch is located in the passage from the filter and controls the oil pressure. If the oil pressure falls below 14 psi. (1.0 kgf/cm²) the oil warning lamp* will light on the dash panel.* If the oil pressure lamp stays on after the engine is running at normal speed, shut the engine off immediately. Find and correct the cause of the low oil pressure before operating again.

If the pressure regulating valve in the filter fails and the pressure rises, a safety valve will limit the pressure to 140 psi. (10 kgf/cm²)

[[Probable cause of low oil pressure]]

- (1) Clearance on one of the bearings is too great.
- (2) One of the rocker arms is too loose.
- (3) Faulty pressure regulating valve; pressure lower than normal (replace the oil filter or clean the valve on the old one with kerosene or diesel fuel.)

16 H.P.

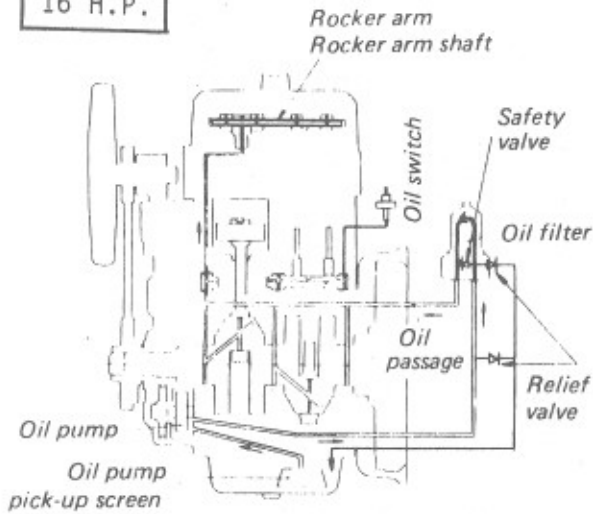

24 H.P.

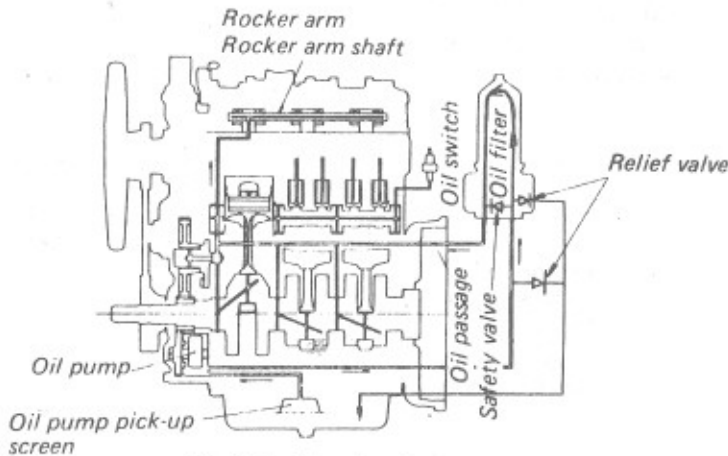

Fig. 8. Lubrication System

■ Oil filter

- (1) Replace the oil filter at every other oil change (every 150 hours)
- (2) Under normal conditions it is only necessary to change the oil filter at the specified intervals. If, however, the engine is used in EXTREMELY dirty conditions, the pressure regulating valve and safety valve should also be removed and cleaned
- (3) Whenever the oil filter is replaced, run the engine under no load for a few minutes until the filter has been filled and then add oil to make up for what is contained in the filter.

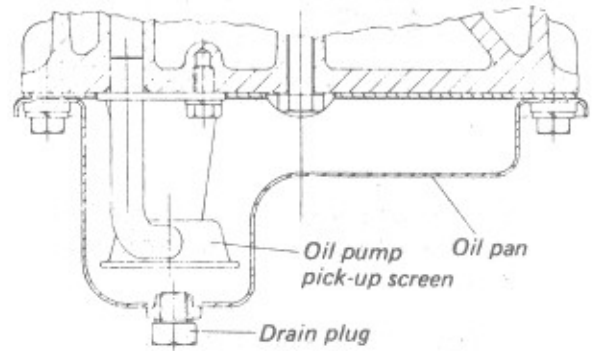

Fig. 9. Detail of Oil Pump Pick-up

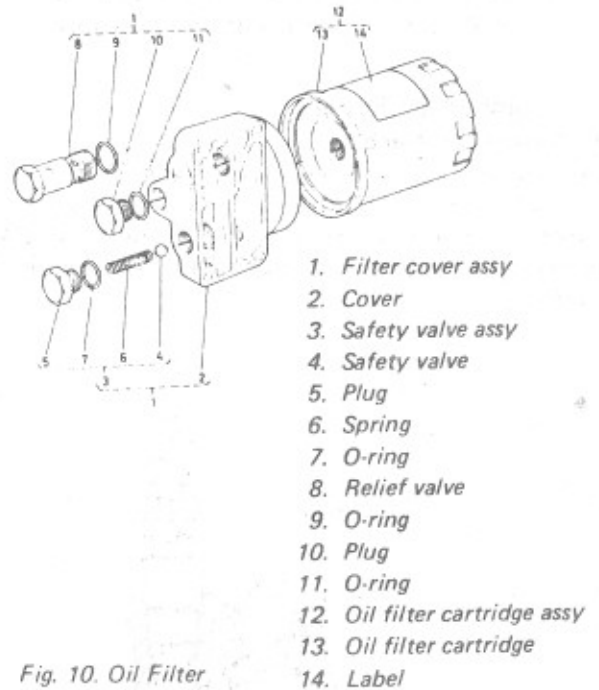
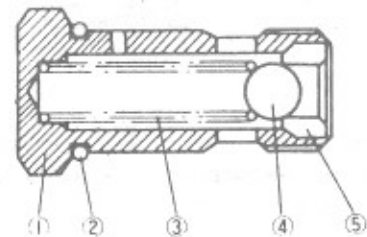
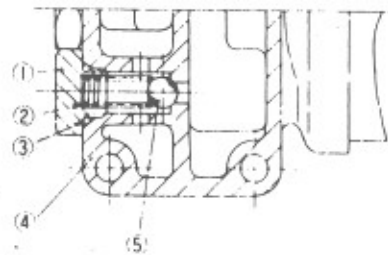

Fig. 10. Oil Filter



1. Relief valve comp.
2. "O" ring
3. Spring
4. Ball valve
5. Valve sheet

Fig. 11. Pressure Regulating Valve



- 1. Safety valve body
- 2. Safety valve spring
- 3. "O" ring
- 4. Oil filter base
- 5. Safety valve

Fig. 12. Safety Valve, Complete

■ Replacing engine oil

- (1) Drain and replace the engine oil after the first 35 hrs of operation and every 75 hrs thereafter.
- (2) The oil is easier to change if the engine is warm.
- (3) Do not mix different brands of oil. If a different brand of oil must be used, drain the oil and replace with all one brand. Also, do not mix oils of different viscosities.

Combustion System

■ Combustion chamber

The engine utilizes a swirl type pre-combustion chamber

See (Fig. 13). Fuel and air are mixed in this chamber resulting in more efficient combustion. A glow-plug is employed to preheat the fuel for easy starts down to 5°F (-15°C).

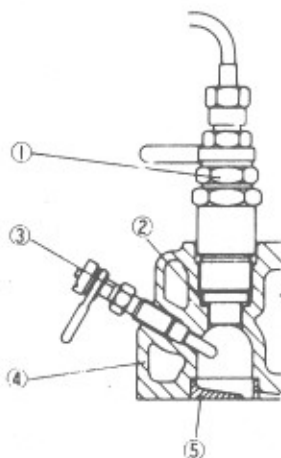

- 1. Nozzle holder
- 2. Nozzle piece packing
- 3. Glow plug
- 4. Cylinder head
- 5. Combustion chamber

Fig. 13. Combustion Chamber

■ Valve

Combustion air, of course, is brought in through the intake valve when the descending piston creates a partial vacuum in the cylinder.

Valve stem seals should be replaced whenever they are removed. If the stem seal are replaced, coat the stem liberally with oil before inserting in the valve guide to prevent burning the valve stem seal.

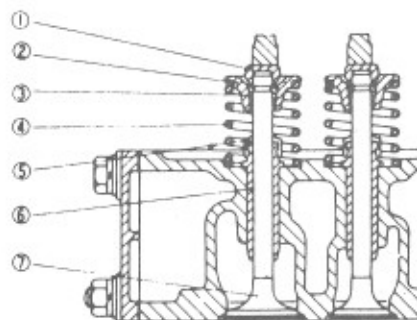

- 1. Valve cap
- 2. Valve spring retainer
- 3. Valve spring collet
- 4. Valve spring
- 5. Valve stem seal
- 6. Valve guide
- 7. Valve

Fig. 14. Structure of Valves

The dimensions of the replacement valves and valve guides are shown in Fig. 15. When new valve guides are installed, the bores should be reamed to 0.316 to 0.315 in. (8.030 to 8.015mm) after installation. The valve head must be recessed 0.043 to 0.055 in. (1.1 to 1.4mm) from the face of the cylinder head to prevent it from hitting the top of the piston.

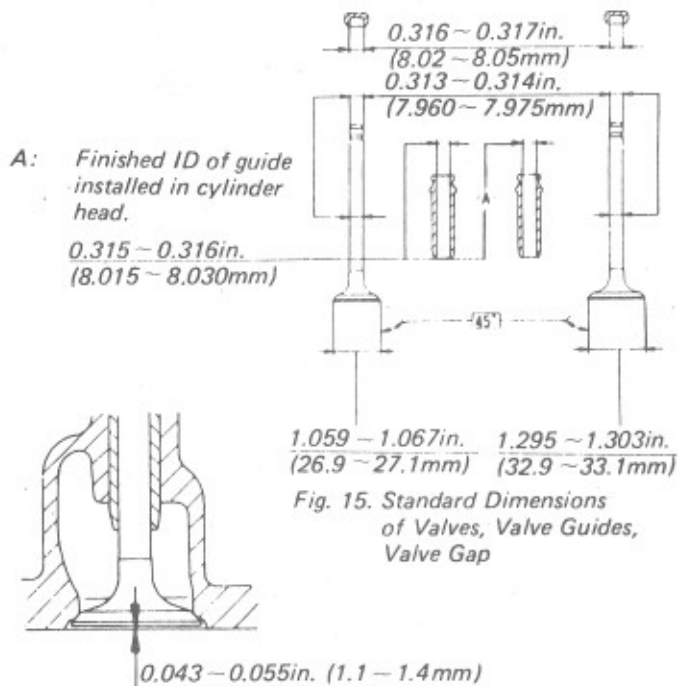

Fig. 15. Standard Dimensions of Valves, Valve Guides, Valve Gap

Fig. 16. Sinking of Valve

■ Valve timing

When the valve clearance has been adjusted as shown in Fig. 17, the standard valve timing shown in the chart can be attained:

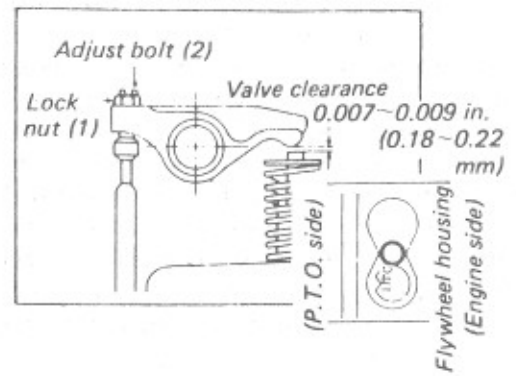

Fig. 17. Adjustment of Valve Clearance

Intake valve opens	20° B TDC
Intake valve closes	45° A BDC
Exhaust valve opens	50° B BDC
Exhaust valve closes	15° A TDC

Valve clearance: 0.007 to 0.009 in. (0.18 to 0.22 mm) with engine cold.

■ Rocker Arms

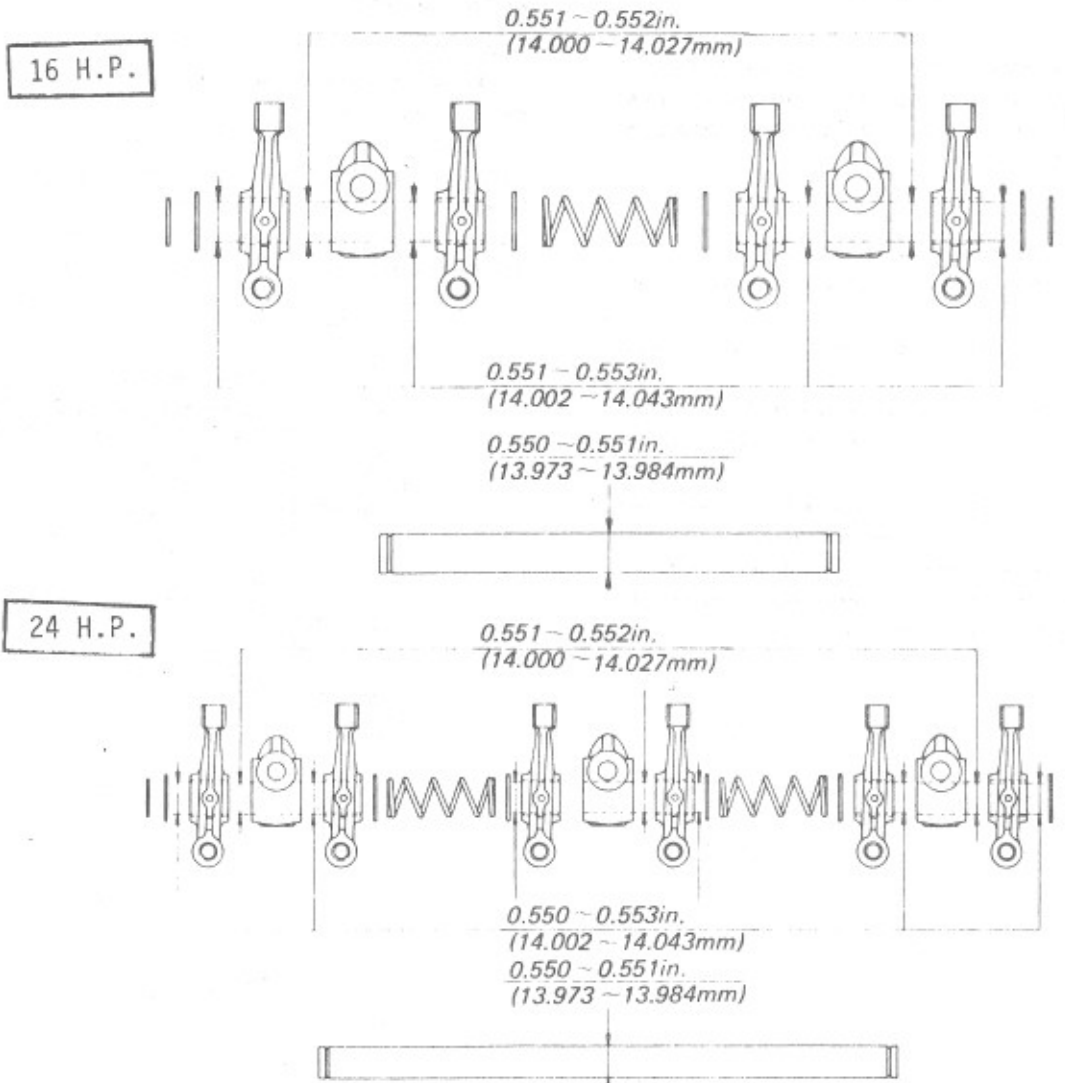

Fig. 18. Standard Relative Position of Rocker Arms

■ **Compression release (Release wire is optional parts)**

Assemble the parts as shown in Fig. 19. Pull the lever out as far as it will go, check to see that the 60° angle is attained and that compression is released. The compression release is to be used when the battery is low or when starting in cold weather. To use the compression release, preheat the glow plug as usual, pull the compression release knob out as far as possible and hold it there while cranking the engine. This partially releases the engine compression enabling it to turn faster in cold weather or when the battery is low. Once the engine is turning fast enough to start, release the lever and the engine will start.

(NOTE)

Make sure the compression release has returned to the operating position by pushing the knob all the way in.



Fig. 19. Compression Released

|| CAUTION ||

Do not pull the compression release lever when the engine is running at high speed or under load. If it is necessary to use the compression release while the engine is running reduce the speed to idle before doing so.

■ **Adjustment of compression release**

- (1) Set exhaust valve in totally closed position.
- (2) Remove decompression adjustment window cover from cylinder head cover.
- (3) Make valve clearance as "0" with use of decompression adjust bolt. From this position, turn the bolt further by 1 to 1.5 turns. Decompression clearance will then be set at 0.030 to 0.044 in. (0.75 to 1.125mm), which is the designed clearance.
- (4) After adjusting, be sure to lock adjust bolt securely so that it will not unturn while engine is in service.
- (5) Make certain that the clearance is not too wide. To check this, turn crankshaft by hand and make certain valve disk does not contact with piston top.

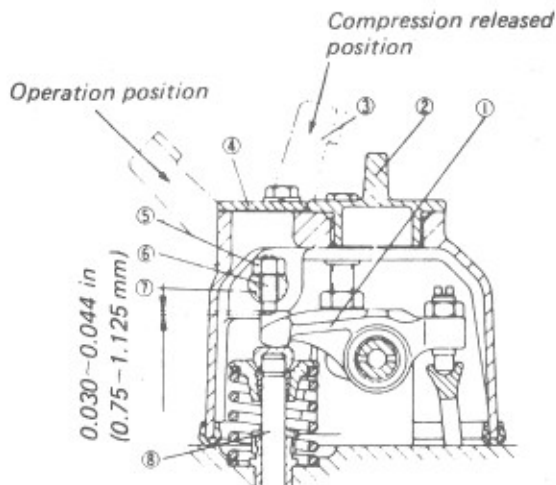

- | | |
|------------------------------|-----------------------------|
| 1. Rocker arm | 5. Compression release nut |
| 2. Oil filler cap | 6. Compression release bolt |
| 3. Compression release lever | 7. Shaft |
| 4. Adjustment access cover | 8. Valve |

Fig. 20. Adjustment of Compression Released

■ **Top clearance**

Top clearance should be 0.028 to 0.035 in. (0.7 to 0.9 mm). To adjust, use cylinder gasket shims, 0.006 in. (0.15 mm) thick each, onto the head side.

For checking the measurement, place a piece of fuse on the piston top and fix the cylinder head securely on the cylinder-head flange. The measurement is taken by the fuse. The liner is level with the cylinder frame at top surface.

The gasket shims can be reused, so do not lose them.

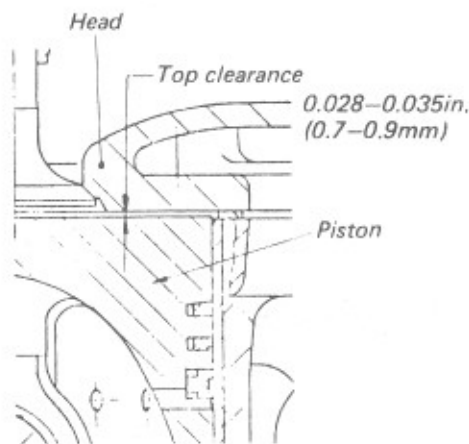

Fig. 21. Top Clearance

■ Boring and replacing the cylinder liner

Referring to Fig. 22, the inside diameter of the liner should be checked at points 1, 2, and 3 and in the directions (a) and (b). The liner on which the wear has exceeded the service limit can be bored and honed to 0.020 in. (0.50mm) oversize. The finished dimensions are 3.012 to 3.013 in. (76.500 to 76.519mm). **Models 5416 and 5424.**

An oversized piston and rings must then be used with this liner. Once this oversized liner has exceeded its wear limit, it should be replaced with a new one. To install a new liner, coat the outside liberally with oil, push into the block with a press and finish to the standard size. When this is done, a standard size piston must again be used.

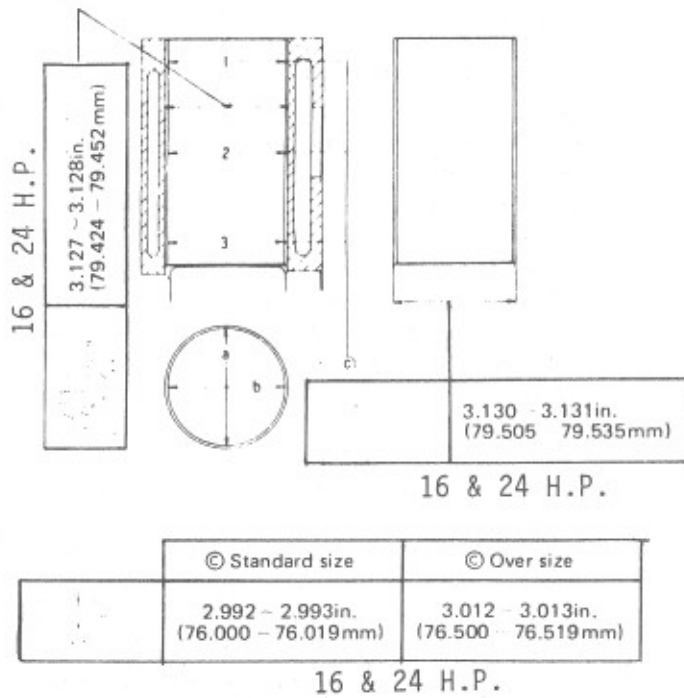

Fig. 22. Standard Dimensions of Cylinder Liner and Liner Bore in Block

■ Tightening cylinder head capscrews (Fig. 23)

- (1) The tightening torque of the cylinder head capscrews is 54 to 58 ft lbs. (7.5 to 8.0 kg-m). Numbers 7, 8 and 11, 13 (◆) in the diagram are studs. The nuts on these studs should also be tightened to this torque.
- (2) All the capscrews must be tightened uniformly. To do this, tighten all the capscrews in the order indicated on the diagram until they are just snug. Then tighten each one 1 (one) turn at a time in this same sequence each time until all have been tightened to the required torque.
- (3) The cylinder head capscrews should be re-tightened if the engine has not been used for a long time. The valve lash should also be adjusted each time the cylinder head capscrews are retorqued. If the cylinder head gasket has been replaced, run the engine for about 30 minutes and re-tighten the cylinder head capscrews as described above.

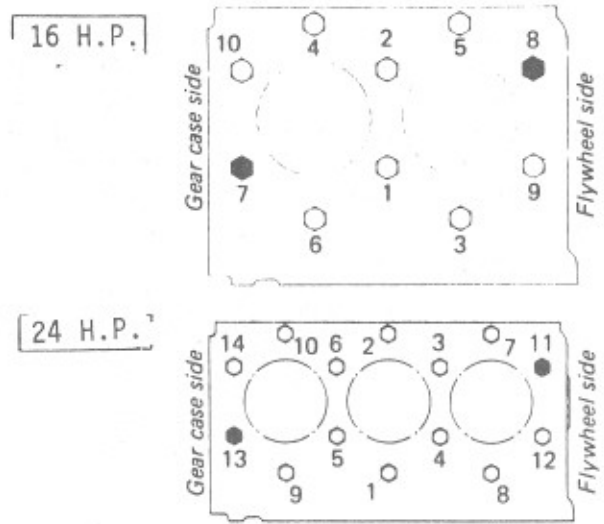

Fig. 23. Tightening of Cylinder Head Bolts

■ Air cleaner

Main Moving Parts

■ Pistons and piston rings

The pistons and piston rings are shown in Fig. 26. If the cylinder liners have been bored oversize, oversize pistons and rings must be used. The piston is made of high silicon Al-Alloy and is cam ground. The top compression ring is a chrome plated keystone type, the second compression ring is discontinuous and undercut and the oil control ring is of the standard expansion type.

- B : End gap of rings on piston in cylinder
 I : Diameter of piston skirt thru \bar{E} of piston pin bore
 E : Diameter of piston skirt perpendicular to piston pin

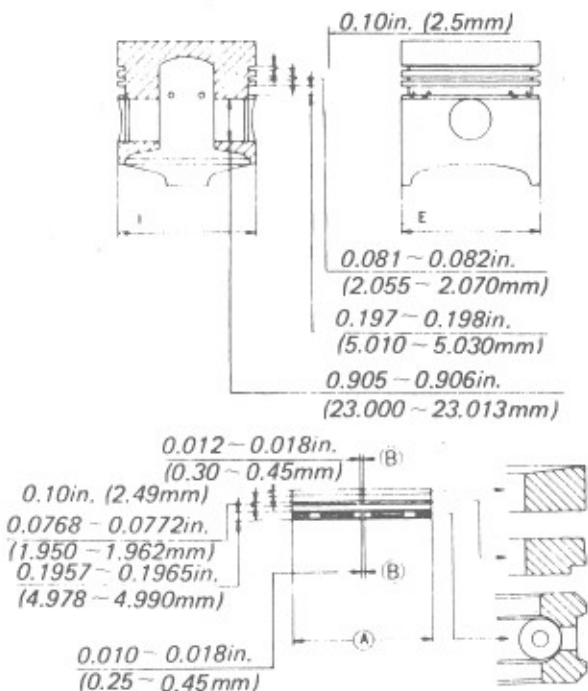

Fig. 26. Standard Dimensions of Piston and Piston Rings

	Standard size	Over size	
(A)	2.992in. (76mm)	3.012in. (76.5mm)	16 H.P.
I	2.986 - 2.987in. (75.839 - 75.859mm)	3.005 - 3.006in. (76.339 - 76.359mm)	
E	2.989 - 2.990in. (75.915 - 75.935mm)	3.008 - 3.009in. (76.415 - 76.435mm)	
			24 H.P.

■ Crankshaft and connecting rod

- (1) The crankshaft is a heat treated steel alloy forging. The crank pins are induction hardened for additional wear resistance. Crankshaft endplay is 0.006 to 0.012 in. (0.15 to 0.31 mm).
- (2) The crankpin bearings are aluminum.

When installing the connecting rods:

- a) Clean both surfaces thoroughly.
- b) Apply engine oil to the threads of the connecting rod capscrews before installing and tighten each to 27 to 30.4 ft-lbs. (3.7 to 4.2 kg-m).

The bearing caps are matched to each connecting rod and should not be interchanged. Also, since there are variations in machining from side to side, each bearing cap and connecting rod are marked and should be assembled so that the marks line up.

- (3) In the event that the crankpins become worn and are no longer serviceable, undersized bearings may be used. When installing the undersize bearings observe the following precautions:

- a) Machine the crankpin diameter and radii to within a few thousandths of the correct dimensions and finish grind to the exact dimensions.
- b) After finish grinding the bearing diameter and the radii, chamfer the diameter of the oil hole with an oilstone. If this is not done an oil film will not form and the bearing will seize.
- c) The crankpin should always be super-finished to 0.000016 in. (0.0004 mm) or less.
- d) Select the bearing from the chart that necessitates the removal of the least amount of metal from the crankpin. Do not deviate from the chart dimensions as the bearing life will be reduced if they are machined.
- e) To determine the running clearance, assemble the connecting rod, bearing cap and bearing as described in section 2 and measure the diameter anywhere within the 120° angle indicated in Fig. 28 and subtract the crankpin diameter from this figure.
- f) The piston pin bushings are of lead bronze. The inside diameter of the bushing should be finished to 0.906 to 0.907 in. (23.025 to 23.040 mm).

Over size	Name of Part		Mark	
0.02in. (0.5mm)	Piston 05 Piston ring 05		05 OS 05 OS	16 H.P. 24 H.P.
	Cylinder liner	3.012 to 3.013in. (76.500 to 76.519mm) (1.2μR max. to 2μR max.) by honing		

16 H.P.

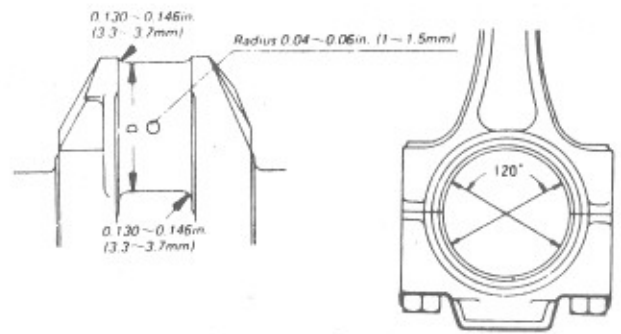
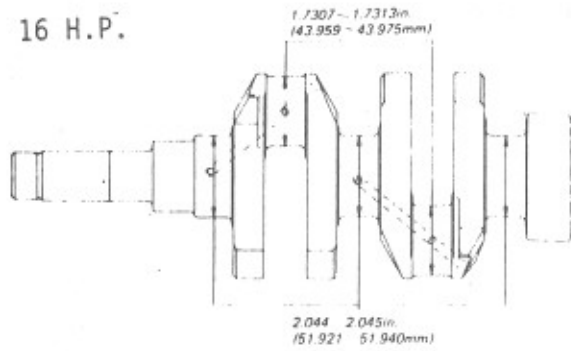
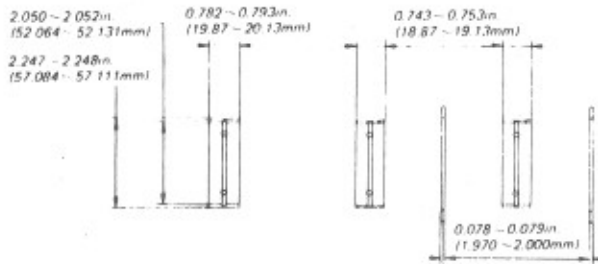

Fig. 28. Crankpin for Undersize Bearing



24 H.P.

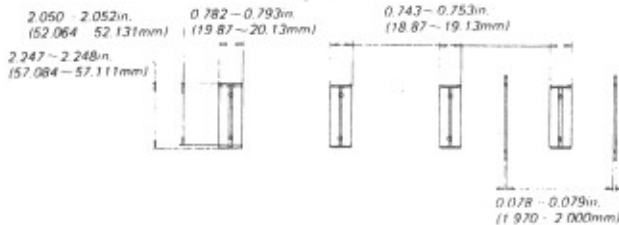
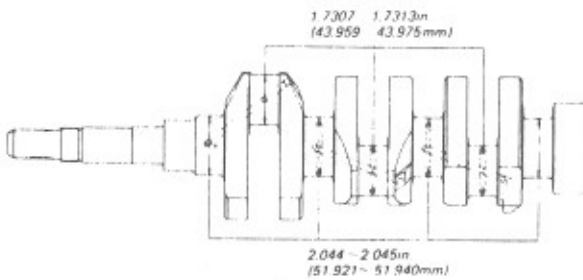
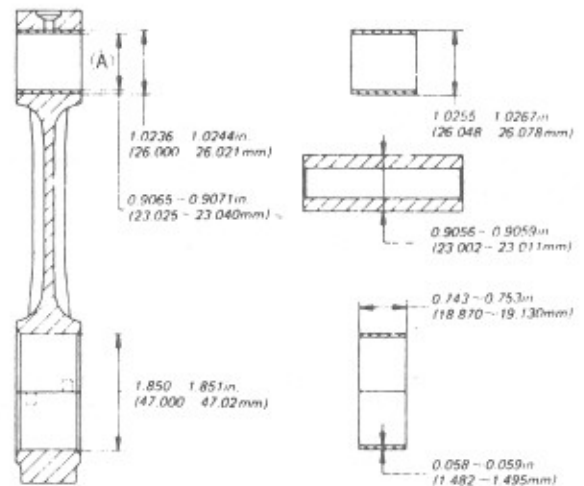

Fig. 27. Standard Dimensions of Crankshaft and Bearings



(A): Diameter of piston pin bushing after installation

Fig. 29. Standard Dimensions of Connecting Rod Bearing and Bushing

Size	Part No.	Bearing	Crankpin Diam.	Metal Mark	Running Clearance in. (mm)
020		0.20 mm undersize	1.7228 to 1.7234 in. (43.759 to 43.775 mm)	020US	0.001379 to 0.003819 in. (0.035 to 0.097 mm)
040		0.40 mm undersize	1.7149 to 1.7156 in. (43.559 to 43.575 mm)	040US	

Main Components

■ Gear train

Be sure to assemble the gears by matching the mating marks as shown in Fig. 30. The backlash of each gear is 0.002 to 0.005 in. (0.0415 to 0.1154 mm)

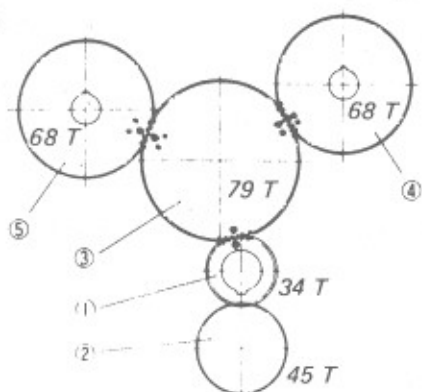

- | | |
|------------------------|-----------------------------------|
| 1. Crankshaft gear | 4. Camshaft gear |
| 2. Oil pump drive gear | 5. Fuel injection pump drive gear |
| 3. Idle gear | |

Fig. 30. Mating Marks of Gear Train

■ Crankshaft gear

Heat to about 176°F (80°C) and slide on crankshaft. If the shaft and bore dimensions are such that the gear will not slide easily, it may be heated to a slightly higher temperature for installation.

■ Camshaft gear

Refer to Fig. 31. Place the camshaft retainer plate on the camshaft first. Shim the camshaft retainer plate out from the camshaft 0.003 to 0.009 in. (0.07 to 0.22 mm) with shims that can be pulled out after the gear is installed. Heat the gear to approximately 176°F (80°C) and slide on the shaft until it butts up against the retainer plate. Remove spacer shims. If the gear will not slide on the shaft easily it too may be heated to a slightly higher temperature as described above.

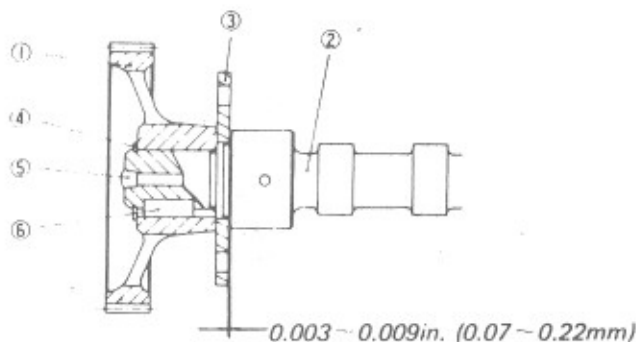

- | | |
|----------------------------|-------------|
| 1. Camshaft gear | 4. Cir-clip |
| 2. Camshaft | 5. Pin plug |
| 3. Camshaft retainer plate | 6. Key |

Fig. 31. Assembly of Camshaft Gear with Camshaft

■ Camshaft and camshaft bearings

Standard dimensions are shown in Fig. 32. Camshaft running clearance is: 0.002 to 0.004 in. (0.05 to 0.091 mm)

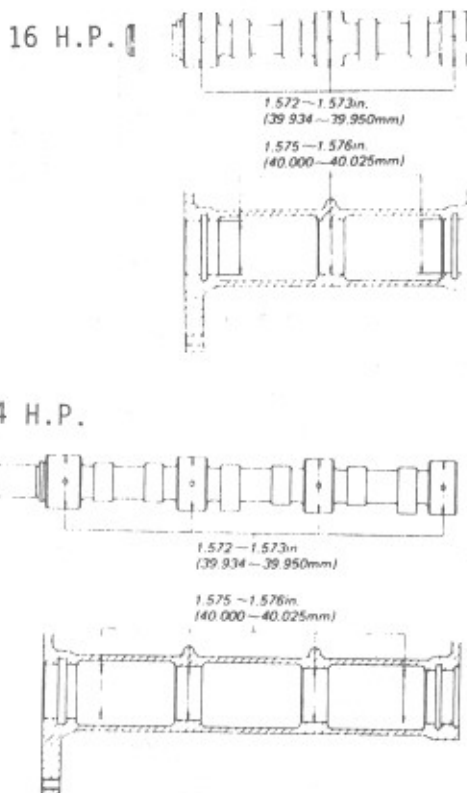
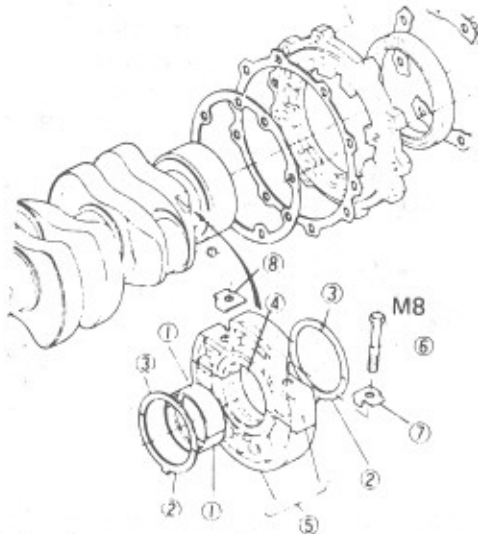

Fig. 32. Standard Dimensions of Camshaft and Bearings

■ **Main bearing ass'y**

Insert the bearings in the main bearing housing halves as indicated in Figs. 33 & 34, using the thrust washers only on the journal nearest the flywheel. Coat the crankshaft journals and the bearing surfaces with engine oil, place the housing halves with bearings on the crankshaft, coat the capscrew threads with engine oil and tighten to 21 to 25 ft-lbs (3 to 3.5 kg-m) —M8



1. Bearing
2. Thrust washer
3. Thrust washer
4. Crankshaft journal
5. Main bearing
6. Cap screw
7. Locking tab
8. Locking tab

Fig. 33. Main Bearing Housing 3 with Thrust Washers

■ **Main bearing housing**

Installation of crankshaft with main bearings in engine block. Slide the crankshaft assembly into the engine block, being careful not to nick or scrape the crankpins. After the assembly is in position make sure the oil passages are correctly lined up. Install the main bearing housing to engine block locking cap screw and washer from the side to position the housing and then install cap screw (2) from the bottom and torque to 47 to 50 ft-lbs (6.5 to 7 kg-m) — M10

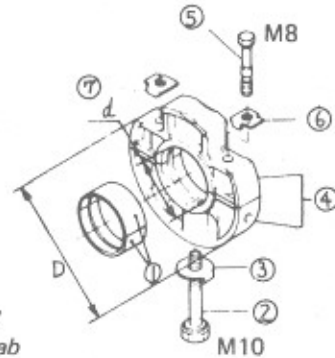

1. Bearing
2. Cap screw
3. Locking tab
4. Main bearing housing
5. Cap screw
6. Locking tab
7. Locking tab

Fig. 34. Main Bearing Housing 1
Main Bearing Housing 2

	D	d	
Main bearing housing 1	5.156 - 5.157in. (130.968 - 130.986mm)	2.2047 - 2.2055in. (56.000 - 56.019mm)	16 & 24 H.P.
Main bearing housing 2	5.1956 - 5.1963in. (131.968 - 131.986mm)		24 H.P.
Main bearing housing 3	5.3137 - 5.3144in. (134.968 - 134.986mm)		16 & 24 H.P.

■ **Idler gear**

Secure the idler gear shaft to the engine block with 3 cap-screws, torque to 17 to 20 ft-lbs (2.4 to 2.8 kg-m) and bend tabs of tab washer. Install gear as shown make sure it runs freely, has a running clearance of 0.001 to 0.002 in. (0.020 to 0.054 mm) and 0.008 to 0.020 in. (0.20 to 0.51 mm) end play.

1. Idler gear
2. Spacer
3. Retaining ring
4. Shaft
5. Bushing
6. Spacer
7. Engine block
8. Capscrew
9. Tab washer

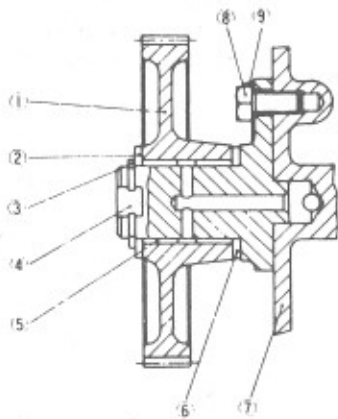
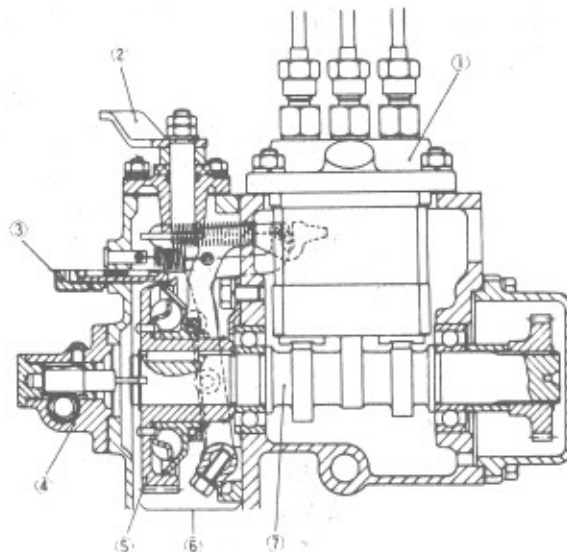

Fig. 36. Idler Gear

■ **Injection pump camshaft**

Injection pump camshaft, Fig. 37. Install the bearings and governor unit on the camshaft and install in the engine block. Hour Meter Unit, Fig. 37. Insert the "tang" on the end of the hour meter drive shaft into the slot on the end of the injection pump camshaft and install as per the illustration.



- | | |
|------------------------|----------------------------|
| 1. Fuel injection pump | 5. Injection pump gear |
| 2. Speed control lever | 6. Governor system |
| 3. Fuel control system | 7. Injection pump camshaft |
| 4. Hour meter unit* | |

Fig. 37. Injection Pump Camshaft Assy

NOTE

*Hour meter unit is optional parts.

■ **Attaching flywheel to crankshaft**

Clean the entire contact surface carefully. Coat the contact surface with engine oil, wash all the oil off with gasoline and dry it thoroughly. Put the flywheel on and torque the capscrews to 70 to 77 ft-lbs (10 to 11 kg-m). Bend the locking tabs back on the washers.

■ **Tensioning of fan belt,**

The fan belt tension is adjusted by moving the alternator bracket in or out. The belt is properly tensioned when the belt deflection midway between the alternator pulley and the crankshaft pulley is 0.25 to 0.35 in. (7 to 9 mm) with a force of 20 lbs applied. Proper belt tension is essential for good engine cooling and belt life. See Fig. 38.

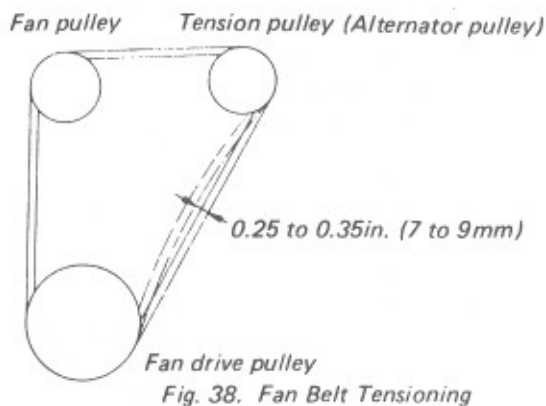

- (1) Rust inhibitor and antifreeze should be used in accordance with the recommendations in the related manuals.
- (2) Be sure to remove all debris that may be plugging the fins.
- (3) Check the rubber shock mount nuts periodically to be sure they are tight.

■ **Cooling water pump**

To install the cooling fan pulley on the pump, securely tighten the nut (4) to 50.6 to 57.9 ft-lbs. (7 to 8 kgf-m) torque.

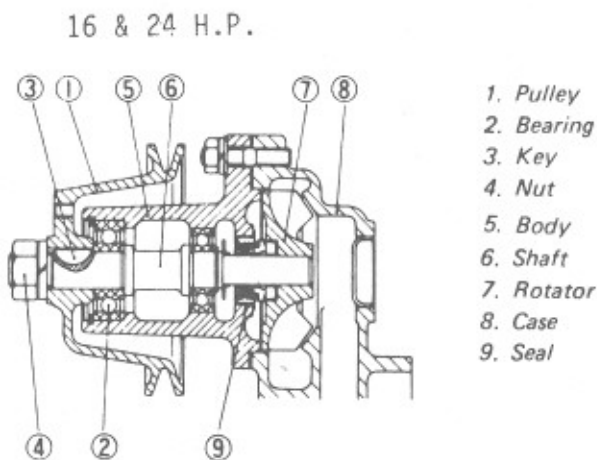

Starting Motor

The starting motor is of the standard bendix type drive with actuating solenoid. The assembly is shown in Fig. 43.

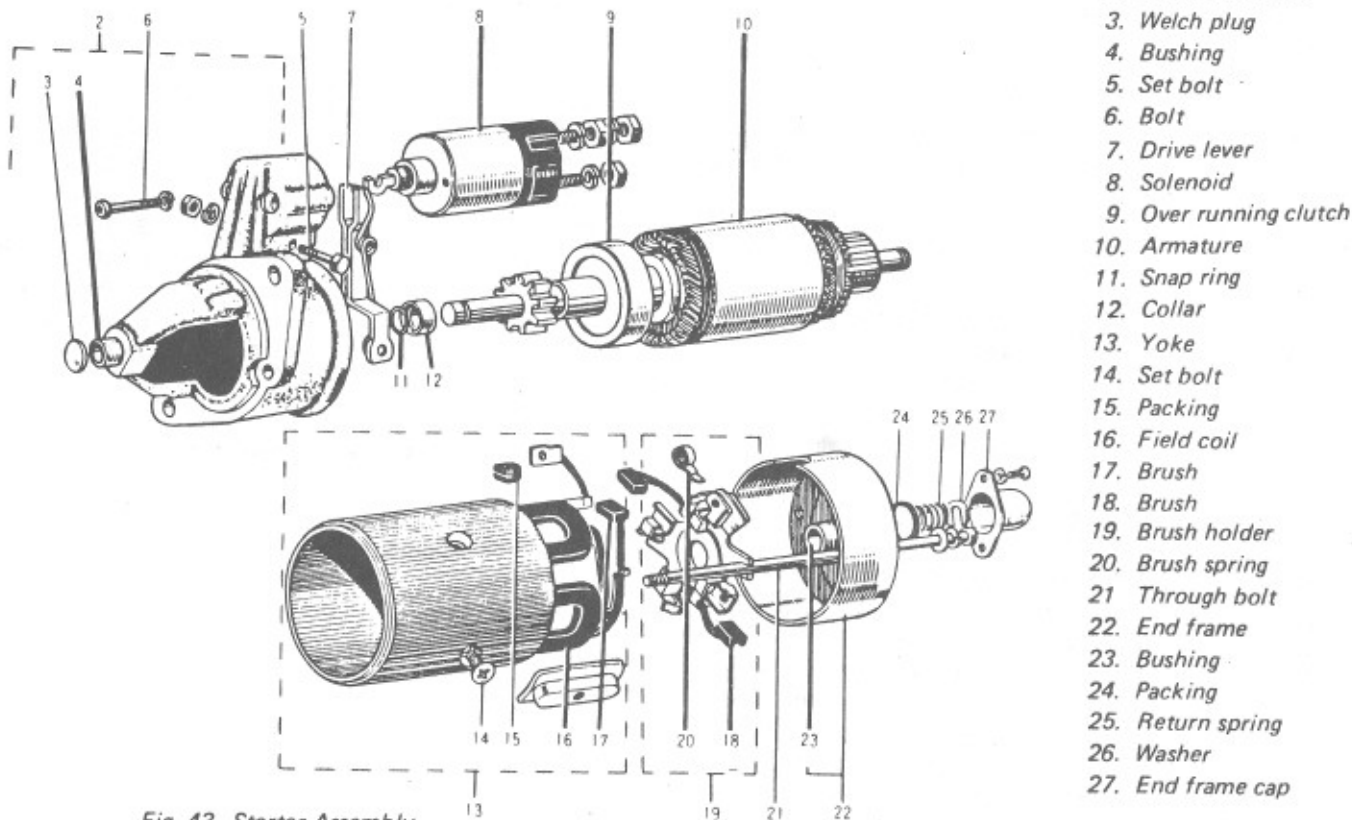

■ Starter specifications

	16 H.P.		24 H.P.
Code No.	298783		298876
Type	Solenoid actuated with overrunning clutch		
Nominal voltage	12V		
Nominal output	0.8 kW		1.0 kW
Direction of rotation	Clockwise, viewed from pinion end		

■ Trouble shooting

If the battery turns extremely slow or not at all, the cause may lie in the battery, wiring or the starter. The lights are a very convenient tool for tracing the cause of the trouble.

Light method

The use of this method, of course, assumes that the lights are functioning normally.

(1) Lights are dim

Probable cause: Low battery, faulty contact at one of the connections, faulty wiring. If the battery remains discharged because of a malfunction in the charging system, it should be corrected before charging the battery to prevent the problem from reoccurring.

(2) With battery fully charged:

a) Symptom: Lights do not light

Probable cause: Battery terminal not properly connected

b) Symptom: Lights become extremely dim when cranking the engine and starter slows down or stops

Probable cause:

- * Bad engine (rotational resistance too great)
- * Starter does not turn satisfactorily:
 - Armature shaft bent
 - Worn bushing
 - Pole core screw loose
- * Field coil grounded or insulator short circuited
- * Armature coil grounded or insulator short-circuited

c) Symptom: Lights are bright but starter does not turn or turns very slowly.

Probable causes:

- * Starter terminal not connected properly
- * Solenoid switch not making contact
- * Solenoid not working (coil grounded or insulator short circuited)
- * Faulty starter switch contact

* Insufficient brush contact

* Dirty or worn commutator

■ Precautions in care and handling of starter motor

- (1) The starting motor must be installed properly for the starter pinion to mesh with the engine ring gear as it should. If the ring gear and pinion do not mesh properly, the pinion and starter housing may be damaged and in extreme cases, the starter may not even turn.
- (2) If the starter switch is turned on and the engine turns, but will not start, the cause is probably in the fuel system. Check the fuel lines and correct as necessary.
- (3) In attempting to start an engine, never use the starting motor for more than 30 seconds at a time without a pause to let it cool down. The starting motor heats up very rapidly when used and if it is used continuously for more than 30 seconds the solder may melt from the armature or the coil or lead wires may melt. Also, the battery will be discharged to such a degree and won't have sufficient power for another attempt at starting. A good rule to follow is to crank for 10 seconds and pause for 10 seconds. Repeat until the engine starts.
- (4) If the starting motor is too far forward, the pinion will not mesh properly with the ring gear and cause rapid piston wear. Adjust for proper mesh.
- (5) Do not turn the starter switch while the engine is running. If this is done, the pinion gear will contact the ring gear, which is turning with the full force of the engine which may cause a broken pinion, bent shaft, broken housing, etc.

Glow Plugs

The glow plugs are the sheath type with the wiring diagram as shown in Fig. 44.

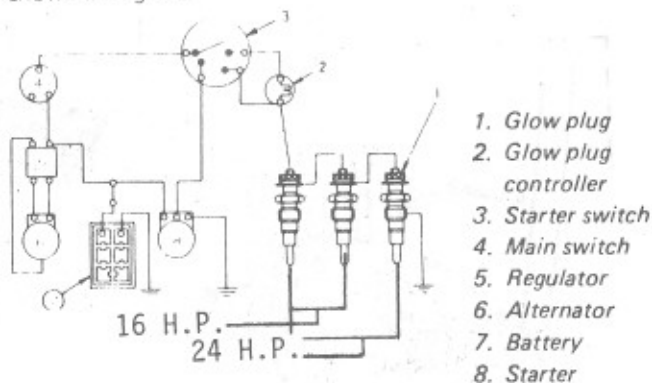

Fig. 44. Circuit Diagram for Glow Plugs

■ Glow plug specifications

	16 H.P.	24 H.P.
Code No.	298795	
Number	2	3
Voltage & current	Approximately 6.5 amp @ 10.5 V	

■ Glow plug controller specifications

	16 H.P.	24 H.P.
Code No.	299839	299839
Current	13A	20A

■ Precautions in handling the glow plug

- (1) Use the glow plugs only with **Universal** glow plug controller. If any other type is used, the heating time will not match that of the glow plugs and cause hard starting and various other problems.
- (2) As the glow plugs are in parallel, the controller heating element will turn red even if one of the plugs is bad. However, the time it takes for the controller heating element to get hot is less, which will cause the element to burn out.
- (3) Replacing a faulty glow plug may not solve all the system problems. Should the failed plug indicate problems in other areas beside the plug, they should be checked out also. The most probable areas are: improper fuel injection timing, bad nozzle, wrong fuel, incorrect circuit connection, gas leak, etc.

Universal Diesel

ENGINE CONNECTIONS

PANEL CONNECTIONS

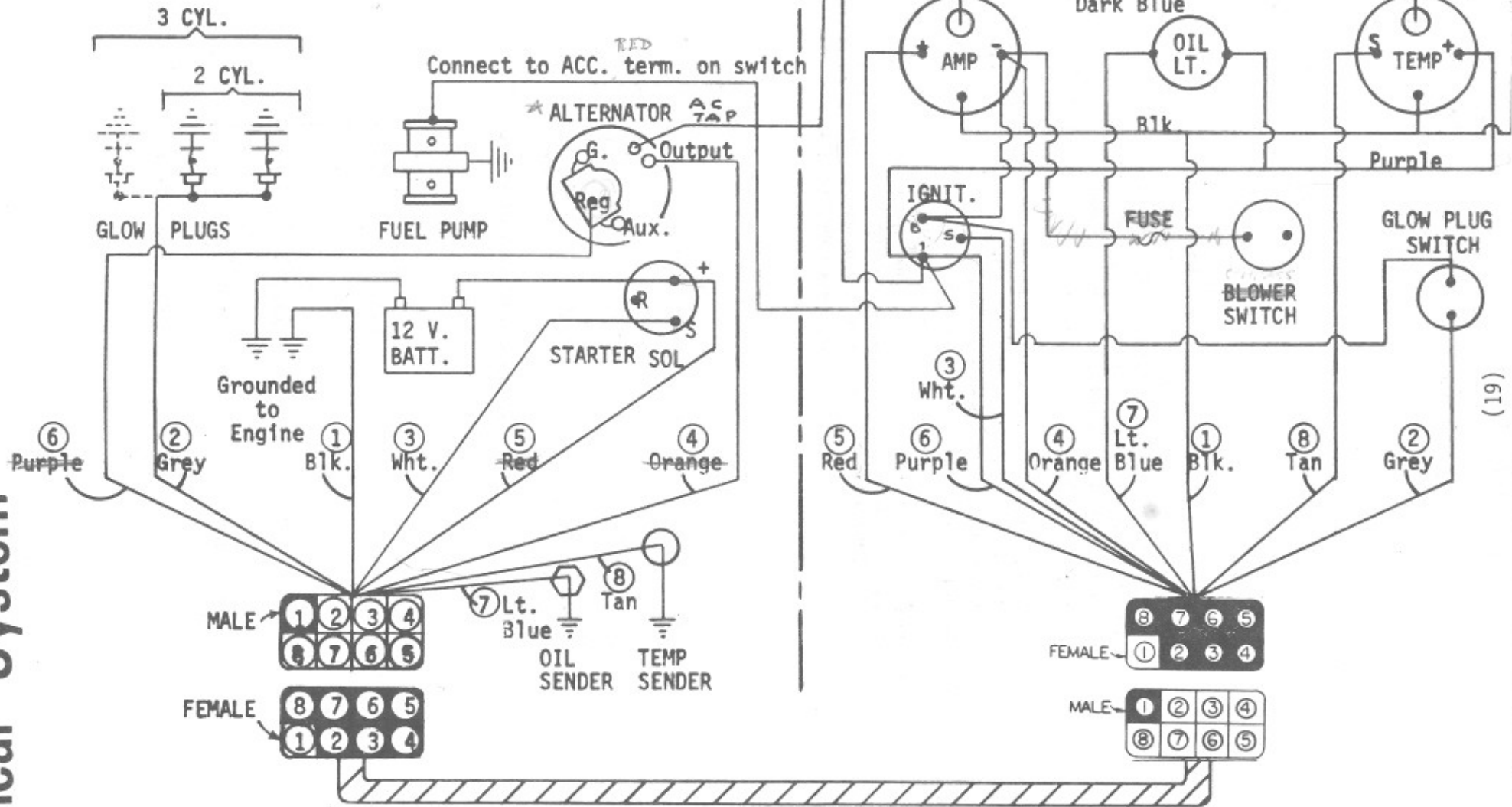

*- SEE BATT. CONNECTION DWG.
FOR ALT. WIRING.



Electrical System

Reference Chart

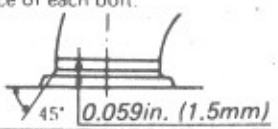
Engine

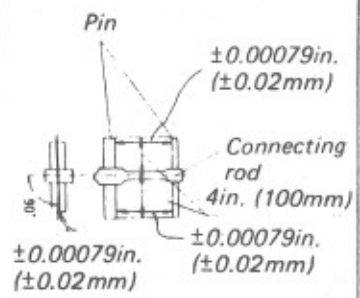
Parts	Items	Specifications	Standard Value	Maximum Limit	Remarks	
Cylinder Head	Cylinder head tightness	M10 x 1.25	54.2 ~ 57.9 ft. lbs. (7.5 ~ 8 kg-m)		When installing, apply a generous coat of engine oil onto the entire surface of each bolt. 	
	Cylinder head surface distortion		0.002 in. below (0.05 mm below)			
	Intake/exhaust valve seat thickness	45° 0.059 in. (1.5 mm)				
	Top clearance		0.0276 ~ 0.0354 in. (0.7 ~ 0.9 mm)			
Cylinder Liner	Standard ID	5416 & 5424	2.9921 - 2.9929 in. (76.000 - 76.019 mm)	2.9980 in. (76.15 mm)	0.050 oversize liner ID 3.0118 - 3.0126 in. (76.500 - 76.519 mm)	
	Piston clearance (At piston skirt)	5416 & 5424	0.0026 - 0.0041 in. (0.065 - 0.104 mm) E side 0.0056 - 0.0071 in. (0.141 - 0.180 mm) I side			
	Type		Dry		Height above block surface ± 0.00098 in. (± 0.025 mm)	
Piston	Standard OD	5416 & 5424	2.9921 in. (76 mm)		Oversize 0.020 in. (0.5 mm)	
	Piston-pin boss ID		0.9055 ~ 0.9060 in. (23.000 ~ 23.013 mm)	0.9071 in. (23.04 mm)		
	Piston-pin clearance		interference 0.0004 in. (0.011 mm)	Clearance 0.0004 in. (0.011 mm)		
Piston Ring	Ring gap	(top, 2nd) (oil ring)	0.0118 - 0.0178 in. (0.3 - 0.45 mm)	0.0492 in. (1.25 mm)	0.5 oversize top ring surface should be 0.0079 in. (0.2 mm) below piston side surface. 	
	Top ring width	Keystone type	0.0098 - 0.0158 in. (0.25 - 0.45 mm)			
	2nd ring width		Ring groove clearance 0.0037 ~ 0.0047 in. (0.093 ~ 0.120 mm)			
	Oil ring		0.0008 ~ 0.0020 in. (0.02 ~ 0.052 mm)			
Piston Pin	OD		0.9056 ~ 0.9059 in. (23.002 ~ 23.011 mm)			
	Pin-to-bush clearance		0.0006 ~ 0.0015 in. (0.014 ~ 0.038 mm)	0.0059 in. (0.15 mm)		
Connecting Rod	Small end ID		1.0236 ~ 1.0244 in. (26.000 ~ 26.021 mm) (without bush)		 When installing, apply a generous coat of engine oil onto the entire surface of each bolt.	
	Small end width		1.0236 in. (26 mm)			
	Large end ID		1.8504 - 1.8512 in. (47.000 ~ 47.020 mm) (without bush)			
	Large end width		1.0079 ~ 1.0118 in. (25.6 ~ 25.7 mm)			
	Rod torsion (see diagram)			0.0008 in. (0.02 mm)		0.002 in. (0.05 mm)
	Rod bolt torque		M8 x 1	26.76 ~ 30.38 ft. lbs. (3.7 ~ 4.2 kg-m)		

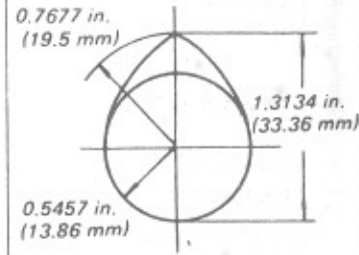
Parts	Items	Specifications	Standard Value	Maximum Limit	Remarks
Crank pin Metal	ID	1.7327 ~ 1.7345 in. (44.01 ~ 44.056 mm) (with metal)			Center thickness 0.0583 ~ 0.0589 in. (1.482 ~ 1.495 mm) Crank arm-to-large end clearance
	Width	0.7429 ~ 0.7531 in. (18.87 ~ 19.13 mm)			
	OD	1.85 in. (47 mm)			
	Running clearance		0.0014 ~ 0.0038 in. (0.035 ~ 0.097 mm)	0.0079 in. (0.2 mm)	
	Axial clearance		0.0157 ~ 0.0236 in. (0.4 ~ 0.6 mm)		
Crankshaft Main Bearing	Crankshaft jurnal dia.	2.0441 ~ 2.0449 in. (51.921 ~ 51.94 mm)	Running clearance 0.0016 ~ 0.0041 in. (0.04 ~ 0.104 mm)	0.0079 in. (0.2 mm)	
	Main bearing ID	2.0465 ~ 2.0483 in. (51.98 ~ 52.025 mm) (with metal)			
	Crankshaft metal (2) width	0.7429 ~ 0.7531 in. (18.87 ~ 19.13 mm)			
	Crankshaft jurnal dia.	2.0449 ~ 2.0449 in. (51.921 ~ 51.94 mm)	Running clearance 0.0016 ~ 0.0046 in. (0.04 ~ 0.118 mm)	0.0079 in. (0.2 mm)	
	Gear-side main bearing ID	2.0465 ~ 2.0488 in. (51.98 ~ 52.039 mm) (with metal)			
	Crankshaft metal (1) width	0.7823 ~ 0.7925 in. (19.87 ~ 20.13 mm)			
	Crankshaft metal (1) OD	2.2485 ~ 2.2474 in. (57.111 ~ 57.084 mm)			
	Crank-pin jurnal dia.	1.7307 ~ 1.7313 in. (43.959 ~ 43.975 mm)		0.0047 in. (0.12 mm)	
Crankshaft side clearance		0.0059 ~ 0.0122 in. (0.15 ~ 0.31 mm)			
Crank bearing cap bolt (1) torque	M 8 x 1.25	21.7 ~ 28.3 ft. lbs. (3 ~ 3.5 kg-m)			
Crank bearing cap bolt (2) torque	M 10 x 1.25	47.0 ~ 50.6 ft. lbs. (6.5 ~ 7 kg-m)			
Cam Shaft	Cam bearing ID	1.5748 ~ 1.5758 in. (40.000 ~ 40.025 mm)	Running clearance 0.0020 ~ 0.0036 in. (0.05 ~ 0.091 mm)		
	Cam shaft dia.	1.5722 ~ 1.5728 in. (39.934 ~ 39.950 mm)			
	Axial clearance		0.0028 ~ 0.0087 in. (0.07 ~ 0.22 mm)		
	Cam lift	0.2165 in. (5.5 mm)			
	Cam height	1.3134 in. (33.36 mm)			

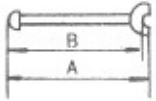
Parts	Items	Specifications	Standard Value	Maximum Limit	Remarks
Timing Gear	Number of teeth, crank gear	34			
	Number of teeth, idel gear	79			
	Number of teeth, cam gear	68			
	Number of teeth, Injection pump gear	68			
	Number of teeth, oil pump drive gear	45			
	Backlash			0.00163~0.00454 in. (0.0415~0.1154mm)	0.0118 in. (0.3 mm)
Valve	Shinkage	0.0433 ~ 0.0551 in. (1.1 ~ 1.4mm)			
	Face angle	45°			
	Intake bore	1.2953~1.3031 in. (32.9 ~ 33.1 mm)			
	Exhaust bore	1.0591~1.0669 in. (26.9 ~ 27.1 mm)			
	Stem dia.	0.3134~0.3140 in. (7.960~7.975mm)			
	Valve guide ID	0.3156~0.3161 in. (8.015~8.030mm)			
	Stem guide clearance		0.0016~0.0028 in. (0.04 ~ 0.07 mm)		
	Valve clearance		0.0071~0.0087 in. (0.18 ~ 0.22 mm)		When cold.
Valve Spring	Free length	1.6417~1.6614 in. (41.7 ~ 42.2 mm)			
	Spring pressure		26.46 lbs /1.3839in. (12kg/35.15 mm)		Load and length when installed.
	Perpendicularity			3%	
	Spring pressure loss when installed			15%	
Push Rod	Over-all length	A: 5.984 in. (152 mm) B: 5.8189~ 5.8346 in. (147.8~ 148.2 mm)			
	Dia.	0.2323~0.2402 in. (5.9 ~ 6.1 mm)			

Parts	Items	Specifications	Standard Value	Maximum Limit	Remarks
Valve Timing	Intake valve opened Intake valve closed Exhaust valve opened Exhaust valve closed Ignition process Injection timing		At 20° BTDC At 45° ABDC At 50° BBDC At 15° ATDC 1-2 1-2-3 25°~26° BTDC		16 H.P. 24 H.P.
Oil pump	Trochoid tooth width Outer rotor OD Trochoid to body clearance Trochoid to body side clearance Oil pressure Pump capacity	16 H.P. 0.5866 - 0.5874 in. (14.90 - 14.92 mm) 24 H.P. 0.8622 - 0.8630 in. (21.90 - 21.92 mm) 1.9669 ~ 1.9685 in. (49.96 ~ 50.00 mm)	0.0035~0.0063 in. (0.09 ~ 0.16 mm) 0.0039~0.0059 in. (0.10~0.15 mm) 64 ~ 71 psi. (4.5 ~ 5 kgf/cm ²) 16 H.P. 4.2 Gallon/min. (16ℓ/min.) 24 H.P. 5.8 Gallon/min. (22ℓ/min.)		Use Engine Oil CD (DS) Above 77°F (25°C), SAE30 Between 32°F ~ 77°F (0°C ~ 25°C), SAE20 Below 32°F (0°C), SAE10W, 10W-30 16 H.P. At pump 2116 r.p.m. 24 H.P. At pump 2000 r.p.m.,
Fuel Injection Pump	Model Injection pressure Pump plunger dia. Pump stroke Pump discharge		NP-PFR3K55/2NP2 1990 psi. (140kg/cm ²) 0.2165 in. (5.5mm) 0.2756 in (7 mm) 0.0013~ 0.0015 in ³ /rev (23 ± 1 mm ³ /rev)		Cam speed: 1400 r.p.m. Rack position: 0.354 in (9 mm)
Injection Nozzle	Model Injection pressure		ND-DN12SD12 1990 ~ 2133 psi. (140~150kgf./cm ²)		

Parts	Items	Specifications	Standard Value	Maximum Limit	Remarks
Cooling Water System	Cooling system	Natural circulation 16 & 24 H.P. Forced circulation			With pressurized radiator (corrugated)
	Water pump (Z751-BW and DH1101-B)	Centrifugal pump with thermostat (impeller)			
	Gear case to impeller clearance		0.0232~0.437 in. (0.59 ~ 1.11 mm)		Water temperature 80°C, Total lift 19.34 lbs./in ² (1mAg)
	Circulation flow rate (Z751-BW and DH1101-B)		26.4 Gallon/min (100ℓ/min) or more		
	Impeller dia. (Z751-BW and DH1101-B)	2.634~2.642 in. (66.9 ~ 67.1mm)			Pump speed 3450~3550 rpm
	Thermostat actuation temperature (Z751-BW and DH1101-B)	179.6~203°F (82°C ~ 95°C)			*No pump for Z751-B and Z851-B
	Radiator cap pressure		12.8 psi. (0.9kg/cm ²)		
	Fan belt length	HM 40.55in. (1030mm) in perimeter 16 & 24 H.P. HM 41.50in. (1054mm) in perimeter			
Battery	Model	16 H.P. 12V70AH 24 H.P. 12V80AH			16 H.P. } NS70, dry 24 H.P. } N70Z, dry
	Electrolyte specific gravity, discharge	1.120			
	Electrolyte specific gravity, charge	1.280 (68°F; 20°C)			
	Electrolyte specific gravity, overdischarge	1.30			
Dynamo	Voltage	12V			Alternator
	Current	20A			
	Check interval	Every 1000 service hours.			Insulation resistance
	Brush spring pressure		12.8 psi(0.9kg/cm ²)	± 15%	
	Insulation resistance				No failure at 500MV
Voltage Regulator	Constant voltage		13.8 ~ 14.8V		
	Current		10A		
	Cut-in voltage		12.5 ~ 13.5V		

Parts	Items	Specifications	Standard Value	Maximum Limit	Remarks
Starter	Number of teeth, pinion	9			
	Number of teeth, ring gear	89			
	Insulation resistance				No failure at 500MV
	Check interval	Every 1000 service hours			Insulation resistance
	Output	<div style="border: 1px solid black; padding: 2px; display: inline-block;"> 16 H.P. 0.8kW </div> <div style="border: 1px solid black; padding: 2px; display: inline-block;"> 24H.P. 1.0kW </div>			Nominal value
Important Bolt Torque	Head set bolt and nut	M10 x 1.25	54.2 ~ 57.9 ft. lbs. (7.5 ~ 8 kgf-m)		Apply a generous coat of engine oil onto the entire surfaces of all important set bolts.
	Flywheel set bolts	M12 x 1.25	72.3 ~ 79.6 ft. lbs. (10 ~ 11 kgf-m)		
	Crankshaft main bearing set cap bolts	M10 x 1.25	47.0 ~ 50.6 ft. lbs. (6.5 ~ 7 kgf-m)		
	Crankshaft cap bolts	M8 x 1.25	21.7 ~ 25.3 ft. lbs. (3.0 ~ 3.5 kgf-m)		
	Rocker bracket set studs	M8 x 1.25	17.4 ~ 20.3 ft. lbs. (2.4 ~ 2.8 kgf-m)		
	Rod bolts	M8 x 1	26.8 ~ 30.4 ft. lbs. (3.7 ~ 4.2 kgf-m)		
Bolt Torque	General set bolts and studs	M12	57.1 ~ 66.5 ft. lbs. (7.9 ~ 9.2 kgf-m)		All these torques are applied to those S45C bolts and studs which have relief number "7" or punch marks. 
		M10	35.4 ~ 41.2 ft. lbs. (4.9 ~ 5.7 kgf-m)		
		M8	17.4 ~ 20.3 ft. lbs. (2.4 ~ 2.8 kgf-m)		
		M6	7.2 ~ 8.3 ft. lbs. (1.0 ~ 1.15 kgf-m)		

Bolt Torques

ft. lbs (kgf-m)

Material Grade Nominal Dia.	Standard Bolt		Special Bolt		Special Bolt	
	SS41, S20C		S43C, S48C (Refined)		SCR3, SCM3 (Refined)	
M 6	5.8 ~ 6.9	(0.80 ~ 0.95)	7.2 ~ 8.3	(1.00 ~ 1.15)	9.0 ~ 10.5	(1.25 ~ 1.45)
M 8	13.0 ~ 15.2	(1.80 ~ 2.10)	17.4 ~ 20.3	(2.40 ~ 2.80)	21.7 ~ 25.3	(3.00 ~ 3.50)
M10	28.9 ~ 33.3	(4.00 ~ 4.60)	35.4 ~ 41.2	(4.90 ~ 5.70)	44.8 ~ 52.1	(6.20 ~ 7.20)
M12	46.3 ~ 53.5	(6.40 ~ 7.40)	57.1 ~ 66.5	(7.90 ~ 9.20)	75.9 ~ 86.8	(10.50 ~ 12.00)
M14	79.6 ~ 92.6	(11.00 ~ 12.80)	91.1 ~ 108.5	(12.60 ~ 15.00)	123.0 ~ 144.7	(17.00 ~ 20.00)
M16	123.0 ~ 141.0	(17.00 ~ 19.50)	144.7 ~ 166.4	(20.00 ~ 23.00)	191.7 ~ 224.2	(26.50 ~ 31.00)
M18	180.8 ~ 209.8	(25.00 ~ 29.00)	202.5 ~ 235.1	(28.00 ~ 32.50)	253.2 ~ 296.5	(35.00 ~ 41.00)
M20	245.9 ~ 289.3	(34.00 ~ 40.00)	271.2 ~ 318.2	(37.50 ~ 44.00)	361.6 ~ 419.5	(50.00 ~ 58.00)

Bolt material grades are shown by numbers punched on the bolt heads.

Prior to tightening, be sure to check out the numbers as shown below.

Punched Number	Bolt Material Grade	
None	Standard Bolts	SS41, S20C
7	Special Bolts	S43C, S48C (Refined)
9	Special Bolts	SCM 3, SCR 3 (Refined)

medalist 

Universal Motors

1552 HARRISON ST. • P.O. BOX 2508

OSHKOSH, WI 54903 • (414) 231-4100 • CABLE: UNIMOT • TLX 262-717